

---

---

# JOURNAL OF THE AMERICAN CHEMICAL SOCIETY

(Registered in U. S. Patent Office) (© Copyright, 1958, by the American Chemical Society)

VOLUME 80

MAY 9, 1958

NUMBER 9

---

---

## PHYSICAL AND INORGANIC CHEMISTRY

[CONTRIBUTION NO. 67 FROM THE THERMODYNAMICS LABORATORY, PETROLEUM EXPERIMENT STATION, BUREAU OF MINES,  
U. S. DEPARTMENT OF THE INTERIOR]

### The Pressure-Volume-Temperature Properties of Fluorobenzene<sup>1</sup>

BY D. R. DOUSLIN, R. T. MOORE, J. P. DAWSON AND GUY WADDINGTON

RECEIVED OCTOBER 14, 1957

Studies of the pressure-volume-temperature ( $P$ - $V$ - $T$ ) properties of fluorobenzene have led to basic data for gas compressibility, critical constants, vapor pressure and orthobaric liquid and vapor density; these data have been correlated by means of the Beattie-Bridgeman equation of state, the Cox vapor pressure equation and Stockmayer's intermolecular potential energy function for polar gases. A detailed description of the experimental method is given.

The rapidly increasing importance of organic fluorine compounds such as the perfluorocarbons can, in many cases, be traced directly to their unique physical and chemical thermodynamic properties. This Laboratory is studying certain key organic fluorine compounds to determine their thermodynamic properties over a wide range of temperature and pressure. Accurate values of the  $P$ - $V$ - $T$  properties and reliable equations of state for the gas at high pressure are required, as well as basic information on the solid, liquid and gaseous states at ordinary pressure.

Fluorobenzene was the first organic fluorine compound selected for study of the  $P$ - $V$ - $T$  properties. The thermodynamic properties in the ideal gas state have been calculated recently, by methods of statistical mechanics, from basic data obtained by low temperature calorimetry, combustion calorimetry, flow calorimetry and vapor pressure measurements.<sup>2</sup> Some  $P$ - $V$ - $T$  properties of fluorobenzene have been determined by Young<sup>3</sup>; however, no systematic investigation of the compressibility in the gaseous region has been reported that is accurate and comprehensive enough to be used as a basis for calculating the thermodynamic properties of the gas at elevated pressures. The relatively high critical temperature of fluorobenzene limits,

considerably, the temperature range available for investigation in the gaseous region and is undoubtedly one of the reasons why no extensive investigation of the gaseous compressibility has been undertaken in the past. The compressibility apparatus used here has a thermostated bath for the bomb that can operate in an inert gas atmosphere up to temperatures in excess of 350° and has therefore made possible accurate compressibility measurements for a considerable portion of the gaseous region in which fluorobenzene is stable. The sample of fluorobenzene showed remarkable stability under the conditions of its confinement. There was no detectable decomposition when it was confined for periods of 24 hours at 350° at pressures as high as 400 atm.

#### Experimental

**Method.**—All measurements were made according to the accurate methods described by Beattie.<sup>4</sup> A known quantity of fluorobenzene (about 0.1 gram-mole) was confined in the Pyrex liner of bomb A, Fig. 1, by mercury forced into the liner through a steel capillary line connecting bomb A with the valves and riser block at F and the mercury compressor D. Details of the bomb with Pyrex-glass liner are shown in cross section, Fig. 2. Pressure measurements, made with the deadweight gauge C, were taken at selected even values of the temperature and molar volume, so that data were obtained along isotherms as well as isometrics. In order to secure data of the highest intrinsic accuracy, all parts of the apparatus were carefully calibrated, and blank-run measurements were made over the entire pressure and temperature range, from 3 to 400 atm. and from 30 to 350°. Finally,  $P$ - $V$ - $T$  measurements were made on water and neopentane and were found to be in good agreement with published work. The calculated over-all accuracy of the measurements varies from 0.03% at the lowest tem-

(1) This research was supported by the United States Air Force through the Air Force Office of Scientific Research of the Air Research and Development Command under contract No. CSO-680-57-4. Reproduction in whole or in part is permitted for any purpose of the United States Government.

(2) D. W. Scott, J. P. McCullough, W. D. Good, J. F. Messerly, R. E. Pennington, T. C. Kincheloe, I. A. Hossenlopp, D. R. Douslin and Guy Waddington, *THIS JOURNAL*, **78**, 5457 (1956).

(3) S. Young, *Proc. Roy. Soc. Dublin*, **12**, 374 (1910).

(4) J. A. Beattie, *Proc. Am. Acad. Arts Sci.*, **69**, 389 (1934).

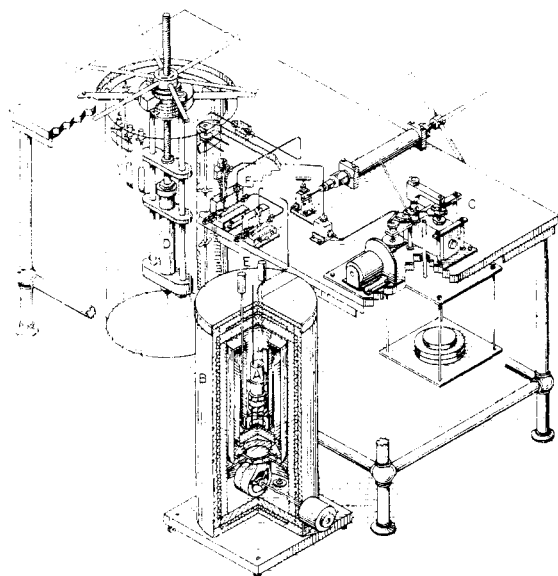

Fig. 1.—The compressibility apparatus.

perature and pressure to 0.3% at the highest temperature and pressure.

**Thermometry.**—The temperature in the bomb was measured with a precision of 0.001° on the International Temperature Scale ( $T, ^\circ\text{K.} = t, ^\circ\text{C. (Int., 1948) + 273.16$ ), by use of a 25 ohm platinum resistance thermometer that had been calibrated by the National Bureau of Standards and checked at the triple-point temperature of a certified benzoic acid cell. Observations of the ice-point resistance  $R_0$  made at the beginning and end of the measurements on fluorobenzene showed no significant change. The ice-point resistance was obtained with the thermometer immersed about 150 mm. into a slush prepared by freezing distilled water with liquid air and decanting the excess water. Corrections were applied to the ice-point resistance  $R_0$  for the effects of atmospheric pressure, specific conductance of the ice-water and depth of immersion of the thermometer in the ice-bath. The resistance of the thermometer was measured with a precision of  $2 \times 10^{-3}$  ohm on a Mueller G-2 bridge and a high sensitivity galvanometer. Each measuring coil in the bridge was calibrated, by the intercomparison of coils, in terms of a 100 ohm standard resistor certified by the National Bureau of Standards to 0.002%.

Fluctuation of the temperature in the bomb during the measurements was  $\pm 0.001^\circ$ . The effect of this small temperature fluctuation was noticeable only at the higher gas densities and in any case was negligible in terms of percentage error in the measurements. At a density of 6 moles per liter, a fluctuation of  $\pm 0.001^\circ$  in the temperature of the bomb caused a corresponding pressure change of about 0.005 atm., or approximately 0.002%. From 30 to 100° an oil-filled thermostat was used, and from 100 to 350° the helium filled thermostat B shown in Fig. 1 was used. Each of these thermostats was regulated by a thyatron tube proportional controller.

**Volume Determination.**—The volumetric mercury compressor D Fig. 1, had a capacity of 215 ml. and delivered approximately 0.7 ml. of mercury for one complete turn of the micrometer screw. Fractional turns of the micrometer screw could be read to the nearest one-thousandth. Actually, the amount of mercury delivered for a given compressor setting was determined by weight calibration to be accurate to 0.004 ml. The compressor was thermostated at  $30 \pm 0.002^\circ$  in a stirred oil-bath, but the temperature of the riser block, connecting lines and valves assumed ambient temperature, which varied from a minimum of 22° to a maximum of 27° and seldom changed more than 1 or 2° in 24 hr. A minor correction of 0.0020 ml. deg.<sup>-1</sup> for this variation was applied to correct the volume of mercury in this part of the system to a standard temperature of 25°. The above correction was applied to the blank run calibration measurements, as well as the compressibility measurements.

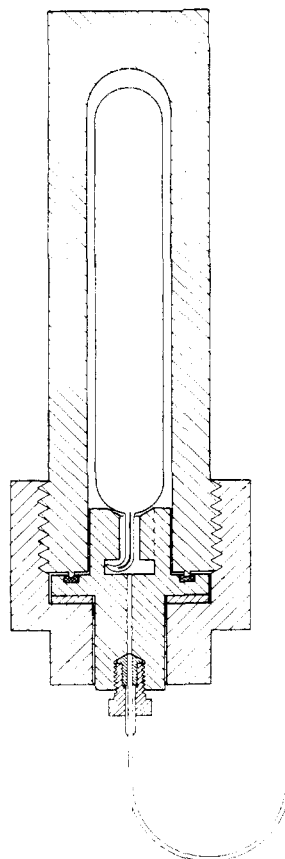

Fig. 2.—Compressibility bomb with glass liner.

The volume of the Pyrex-glass liner was determined to the nearest 0.001 ml. by filling with clean triply-distilled mercury at 30° and weighing. The mercury was introduced by a vacuum technique. A volume correction of 0.0005 ml. was applied for distention of the liner due to the weight of the mercury. The density of mercury was taken from the values determined by Beattie, *et al.*<sup>5</sup>

Changes in the volume of the compressibility apparatus, caused by changes of pressure and temperature, were compensated for by correction factors determined to the nearest 0.001 ml. in blank run calibration measurements made over the entire temperature and pressure range of the measurements with the entire system filled with mercury. A slight adjustment in the value of the bench volume,<sup>4</sup> varying from 0 ml. at 30° to 0.020 ml. at 350°, was made to correct for the effect of temperature on the difference in the zero-set volumes of the blank run and the compressibility run. This difference was assumed to be entirely in the volume of the bomb and to have originated in small differences in the amount of glass sealed off from the capillary tip of the glass liner and the progressive flattening of the iron gasket. The variation in the zero-set volume caused by small differences in the opening of the bomb valve and the riser-block valve was not greater than 0.002 ml. and caused a negligible error of less than 0.0002 ml. in the blank-run factors.

**Pressure Measurement.**—The pressure was determined, with a precision between 0.003% at the lowest pressure and 0.01% at the highest pressure, on an Amagat dead-weight gauge<sup>6</sup> with a 1/4-inch diameter piston made from case-hardened steel. The effective area of this piston and its pressure equivalent per gram of weight were obtained by duplicate calibrations made in terms of the vapor pressure of pure carbon dioxide, 26,144.7 mm. of Hg at 0°.<sup>7</sup> The change of piston area with ambient temperature was calcu-

(5) J. A. Beattie, B. E. Blaisdell, J. Kaye, H. T. Gerry and C. A. Johnson, *Proc. Am. Acad. Arts Sci.*, **74**, 371 (1941).

(6) F. G. Keyes and R. B. Brownlee, "The Thermodynamic Properties of Ammonia," John Wiley and Sons, Inc., New York, N. Y., 1947.

(7) O. C. Bridgeman, *This Journal*, **49**, 1174 (1927).

lated from the temperature coefficient of expansion of steel. In the calibration, corrections were applied for the head of carbon dioxide vapor in the connecting lines, the oil head in the gauge, the mercury head in the separating U-tube and the barometric pressure. All pressure gauge weights were calibrated against a set of Class-S weights certified by the National Bureau of Standards. During the compressibility measurements on fluorobenzene, pressure corrections also were applied for the capillarity of mercury in the riser block, the mercury head from the riser block to the mercury surface in the bomb, and the vapor pressure of mercury  $p_{Hg}$  adjusted for the Poynting effect,

$$2.303RT \log (p_{Hg}/p_{Hg0}) = V(P_g - p_{Hg0}) \quad (1)$$

in which  $V$  is the molal volume of liquid mercury at  $T^\circ K$ , and  $p_{Hg0}$  is the normal vapor pressure of mercury taken from the selected values of Table I. The selected values which were used for the vapor pressure of mercury, shown for even temperatures in Table I, were taken from the literature.<sup>8</sup> The vapor pressure of mercury at temperatures other than those listed in Table I was calculated from equation 36 given by Douglass, *et al.*<sup>5b</sup> All of the above values for the vapor pressure of mercury have been rounded off to the nearest 0.01 mm. The mercury head from the riser block to the P-V-T cell was corrected for variation of density with temperature along the length of the mercury column, and for the acceleration of gravity.<sup>9</sup>

TABLE I

SELECTED VALUES OF THE VAPOR PRESSURE OF MERCURY

$t, ^\circ C.$	$p_{Hg0}, \text{mm.}$	$t, ^\circ C.$	$p_{Hg0}, \text{mm.}$
50	0.01 <sup>a</sup>	225	37.25 <sup>b</sup>
75	.07 <sup>a</sup>	250	74.50 <sup>b</sup>
100	.28 <sup>b</sup>	275	139.64 <sup>b</sup>
125	.95 <sup>b</sup>	300	247.41 <sup>b</sup>
150	2.81 <sup>b</sup>	325	417.33 <sup>b</sup>
175	7.34 <sup>b</sup>	350	674.26 <sup>c</sup>
200	17.27 <sup>b</sup>		

<sup>a</sup> Taken from ref. 8a. <sup>b</sup> Taken from ref. 8b. <sup>c</sup> Taken from ref. 8c.

**Material.**—The sample of fluorobenzene was supplied through the courtesy of Dr. G. C. Finger of the Illinois State Geological Survey Division and was purified by distillation by C. J. Thompson and H. J. Coleman of the Chemistry and Refining Branch of this Station. The sample used for P-V-T studies was a portion of the same material used by D. W. Scott, *et al.*,<sup>2</sup> in their investigation of the thermodynamic properties of fluorobenzene and had a purity of  $99.95 \pm 0.03$  mole % as determined by a calorimetric melting point study. Before the fluorobenzene was transferred, by vacuum distillation, to the glass liner of the bomb, it was dried by passing the vapor over anhydrous magnesium perchlorate and freed from air by the operation of freezing with liquid air and evacuating to at least  $1 \times 10^{-5}$  mm. and melting, carried through three complete cycles. All of the measurements were made on a single sample equal to  $9.09712 \pm 0.00020$  g. or  $0.0946631 \pm 0.000002$  mole.<sup>10</sup>

**Vapor Pressure.**—Values of the vapor pressure of fluorobenzene, obtained from static measurements made with the compressibility apparatus, are given in the second column of Table II for the temperature range from 135° to the critical temperature. Each value obtained with the compressibility apparatus is the average of several pressure measurements taken at different vapor volumes. For example, at 250° the entire sample was in the vapor state at a volume

(8) (a) N. A. Lange, "Handbook of Chemistry," Handbook Publishers, Inc., Sandusky, Ohio, 1944, p. 1440; (b) T. B. Douglass, A. F. Ball and D. C. Ginnings, *J. Research Natl. Bur. Standards*, **46**, 334 (1951); (c) J. A. Beattie, B. E. Blaisell and J. Kaminsky, *Proc. Am. Acad. Arts Sci.*, **71**, 375 (1937).

(9) The acceleration of gravity at this location was calculated from the latitude  $36^\circ 45'$  and the altitude 209 m. to be  $979.82$  cm. sec.<sup>-2</sup>. No topographic or isostatic corrections were applied in this calculation because the sum of these corrections is probably less than  $0.005$  cm. sec.<sup>-2</sup>.

(10) Based upon a molecular weight of 96.100 ( $H = 1.0080$ ,  $C = 12.010$ ,  $F = 19.00$ ). E. Wichers, "Report of the Committee on Atomic Weights of the American Chemical Society," *THIS JOURNAL*, **74**, 2447 (1952).

slightly less than 90 ml., and it was possible to obtain a value for the vapor pressure with any fraction of the sample condensed. The variation of vapor pressure with sample volume is illustrated in Table III for approximately 0.20, 0.52 and 0.85 of the sample condensed. The total variation obtained was insignificant.

TABLE II

THE VAPOR PRESSURE OF FLUOROBENZENE

Temp., $^\circ C.$	Obsd.	Pressure, atm.		Young <sup>c</sup>
		Calcd. eq. 2	Obsd. - calcd.	
84.734	1.000 <sup>a</sup>	1.000	0.000	
96.497	1.414 <sup>a</sup>	1.414	.000	
108.431	1.959 <sup>a</sup>	1.959	.000	
120.538	2.666 <sup>a</sup>	2.665	+ .001	
135.000	3.753	3.750	+ .003	
150.000	5.197	5.196	+ .001	5.170
175.000	8.489	8.487	+ .002	
200.000	13.122	13.122	.000	13.025
225.000	19.412	19.414	- .002	
250.000	27.728	27.728	.000	27.508
275.000	38.563	38.494	+ .069	
275.000 <sup>b</sup>	38.573			
285.000	43.804			
286.000	44.375			
286.500	44.659			
286.600	44.723			
286.700	44.786			
286.800	44.839			
286.900	44.894			
286.920	44.910 (critical)			

<sup>a</sup> Determined by comparative ebulliometry. <sup>b</sup> Made after the compressibility measurements were completed at 350°. <sup>c</sup> Reference 3.

TABLE III

VARIATION OF THE VAPOR PRESSURE WITH VOLUME FOR THE SAMPLE OF FLUOROBENZENE AT 250°

Sample vol., ml.	Fraction condensed	Vapor pressure, atm.
75.017	0.1948	27.730
50.001	.5244	27.728
25.001	.8538	27.728

Each of the static pressure measurements was corrected for the weight of the condensed liquid and for the partial pressure of mercury vapor  $p_{Hg}$  corrected for the effect of total pressure  $P_g$  by the Poynting equation 1.

Included in Table II are values for the vapor pressure below 135° that were taken from a tabulation of ebulliometric measurements previously reported.<sup>2</sup> The normal boiling point taken from the ebulliometric data and the static vapor pressure data above 135°, were used to derive the Cox<sup>11</sup> equation given below

$$\log P(\text{atm.}) = A(1 - 357.894/T) \quad (2)$$

in which

$$\log A = 0.815953 - 5.8347 \times 10^{-4}T + 5.4435 \times 10^{-7}T^2$$

The Cox equation does not deviate from the experimental results by more than 0.003 atm. in the range from 85 to 250°; however, it fails in the critical region and should be used with caution above 250°.

Failure of the Cox equation in the critical region is caused partly by an anomalous increase in the slope  $dP/dT$  of the vapor pressure curve between 286.5 and 286.7°; the slope increases by about 18% of the normal slope taken just below or above this temperature interval. This anomalous increase is not spurious because it exceeds the precision of the measurements in this region by almost a factor of 10. No explanation for this irregularity can be offered at this time, other than the suggestion that it might be related to molecular clustering or a meniscus phenomenon.

(11) E. R. Cox, *Ind. Eng. Chem.*, **28**, 613 (1936).

**Compressibility Measurements in the Critical Region.**—Values for the critical constants and the orthobaric liquid and vapor density of fluorobenzene, given in Table IV, were determined by inspection from the phase-boundary curve of Fig. 3,

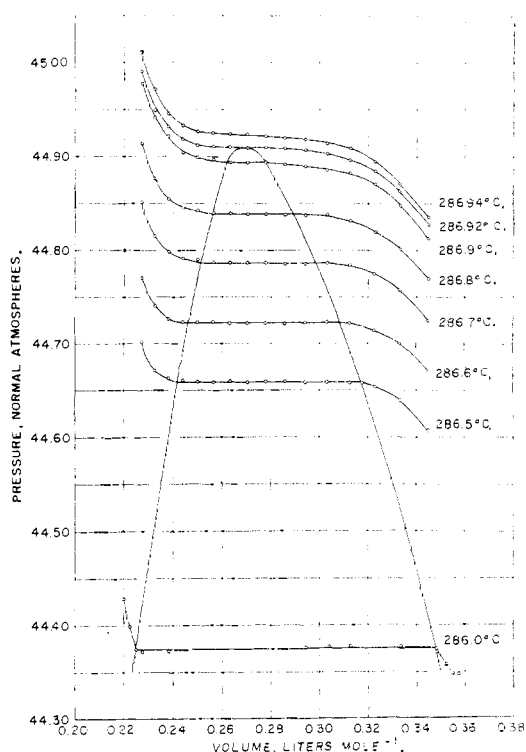

Fig. 3.—Critical region of fluorobenzene.

which was drawn from a plot of the compressibility measurements listed in Table V. Isotherms spaced at intervals of  $0.02^\circ$  were used to bracket the critical point. Young's<sup>3</sup> values for the critical constants, obtained by observing the disappearance of the meniscus, and the orthobaric liquid and vapor density of fluorobenzene agree with the present values within 1%.

TABLE IV  
THE CRITICAL CONSTANTS AND ORTHOBARIC DENSITIES OF FLUOROBENZENE

		Critical constants		
		$t_c^\circ$ , (Int.)	$P_c$ , atm.	$V_c$ , l. mole <sup>-1</sup>
This work		$286.92 \pm 0.05$	$44.910 \pm 0.03$	$0.2688 \pm 0.0027$
Young <sup>a</sup>		286.55	44.621	0.2714
		Orthobaric densities		
$t^\circ$ , (Int.)	This work	Young <sup>a</sup>		
	$d_{liq.}^l$ , g. ml. <sup>-1</sup>	$d_{vap.}^l$ , g. ml. <sup>-1</sup>	$d_{liq.}^l$ , g. ml. <sup>-1</sup>	$d_{vap.}^l$ , g. ml. <sup>-1</sup>
150	0.8544		0.8519	
175	.8150		.8122	
200	.7698		.7671	
225	.7159		.7160	
250	.6541	0.1013	.6504	0.1008
275	.5539	0.1725	.5470	0.1750

<sup>a</sup> Reference 3.

All of the pressure measurements in the critical region were corrected for the weight of the sample. This correction must always be applied to the most

precise measurements; it is nearly always significant in compressibility measurements on dense compounds like the halocarbons and is especially significant when a long (relative to the diameter), cylindrical  $P$ - $V$ - $T$  cell is used. However, a secondary pressure correction for the effect of density gradient in the sample is rarely justified. Density gradient studies, conducted by Palmer<sup>12</sup> in the critical region of carbon dioxide, have indicated that within the accuracy of modern experimental techniques the assumption of a linear pressure gradient is generally adequate. Wentorf<sup>13</sup> has given a method for calculating the density and pressure-gradient corrections for a highly compressible fluid. The largest pressure correction for the primary effect of gravity on the fluorobenzene measurements amounted to 0.0008 atm.; for comparison, the sensitivity in the pressure measurement was about 0.0005 atm. A density-gradient correction to the pressure was ignored, because it was at most 0.0001 atm.

When the pressure corrections for weight of sample were applied in the critical region of fluorobenzene, they caused an apparent narrowing of the vapor-liquid phase boundary and made the isothermal lines horizontal inside this boundary. An experimental verification of the apparent shifting of the uncorrected locus denoting the boundary of the vapor-liquid region, when  $P$ - $V$ - $T$  cells of different lengths and widths were used, has been obtained by Weinberger and Schneider.<sup>14</sup> The two effects mentioned above are demonstrated in a schematic drawing of the critical region, Fig. 4,

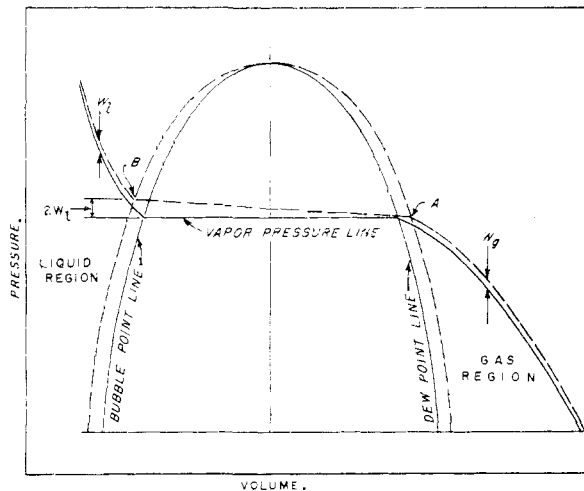

Fig. 4.—Critical region showing how corrections for the effect of gravity were applied. Solid lines represent corrected measurements.

which illustrates how the sample weight corrections were applied. The dashed lines represent uncorrected pressures referred to a point on the surface of the mercury in contact with the fluorobenzene. Providing the top of the  $P$ - $V$ - $T$  cell is approximately a right cylinder, the corrections for the single phase gas or liquid region will be one-half the

(12) H. G. Palmer, *J. Chem. Phys.*, **22**, 625 (1954).

(13) R. H. Wentorf, *ibid.*, **24**, 607 (1956).

(14) M. A. Weinberger and W. G. Schneider, *Can. J. Chem.*, **30**, 442 (1952).

TABLE V

$t$ , °C. (Int.)	Density, mole l. <sup>-1</sup>	Volume, l. mole <sup>-1</sup>	ISOTHERMS IN THE CRITICAL REGION OF FLUOROBENZENE						
			286.50	286.60	286.70	286.80	286.90	286.92	286.94
			Pressure, normal atm.						
2.900	0.3448		44.607	44.671	44.725	44.770	44.813	44.828	44.836
3.000	.3333		44.639	44.700	44.757	44.801	44.848	44.863	44.871
3.100	.3226		44.654	44.714	44.775	44.820	44.870	44.884	44.895
3.150	.3175		44.658						
3.200	.3125		44.658	44.722	44.784	44.832	44.882	44.896	44.908
3.300	.3030		44.658	44.723	44.786	44.838	44.885	44.903	44.914
3.400	.2941		44.658	44.723	44.786	44.837	44.890	44.907	44.918
3.500	.2857		44.659	44.721	44.785	44.838	44.891	44.908	44.919
3.600	.2778		44.659	44.722	44.787	44.838	44.894	44.910	44.921
3.700	.2703		44.659	44.722	44.787	44.839	44.894	44.909	44.923
3.800	.2632		44.660	44.722	44.787	44.839	44.894	44.910	44.924
3.900	.2564		44.659	44.723	44.787	44.840	44.897	44.911	44.925
4.000	.2500		44.659	44.723	44.790	44.843	44.900	44.912	44.926
4.100	.2439		44.661	44.723	44.791	44.846	44.904	44.918	44.933
4.200	.2381		44.663	44.726	44.798	44.855	44.922	44.932	44.946
4.300	.2326		44.671	44.741	44.816	44.877	44.941	44.949	44.972
4.400	.2273		44.701	44.771	44.852	44.914	44.977	44.990	45.012

weight of the sample (converted to the appropriate units of pressure). This correction, labeled  $W_g$  or  $W_l$ , amounted to 0.0004 atm. At the volume A, at which liquid first appears on the mercury surface when the sample is compressed to the dewpoint, no correction to the vapor pressure was necessary. At point B, at which the last gas to condense was a minute bubble at the extreme top of the cell, the measured pressure was corrected by an amount equal to twice  $W_l$  or 0.0008 atm. Between these two points the correction was made proportional to the fraction of the sample which was condensed. The corrected phase boundary, indicated by the solid line, is a smooth curve with apex at the point where both the first and second isothermal derivative of pressure with respect to volume are zero.

#### Compressibility and Equation of State for the Gaseous Region

**Compressibility.**—The compressibility measurements given in Table VI were taken along each isotherm at selected even values of density, first at the lowest density (0.75 mole l.<sup>-1</sup>) and then at regularly increasing values of density to the highest (8.0 mole l.<sup>-1</sup>) over a temperature range from 275 to 350°. By making measurements at even densities, previously selected, any loss of precision during the correlation of the data that would have resulted from crossplotting to even densities was eliminated. The loss of precision from crossplotting can often exceed the precision of the experimental measurements simply because the plotting paper is inaccurately ruled. Reproducibility of the pressure measurements is indicated by the number of significant figures retained in Table VI and is generally greater than the estimated accuracy by about a factor of 10. As a test for reproducibility, after the measurements on each isotherm were completed, the system was returned to 0.75 mole l.<sup>-1</sup> and the pressure measurement was repeated. The greatest difference found was 0.003 atm., and the average difference was 0.001 atm. After all of the compressibility measurements were completed, the system was returned to the initial conditions at 275° and 0.75 mole l.<sup>-1</sup>, and when the

pressure measurements were repeated, a difference of less than 0.001 atm. from the original measurement was found; thus the fact was established that no leakage of mercury from the system or decomposition of the sample had occurred during the entire course of the compressibility measurements.

The method used in this investigation to correct for the effect of mercury vapor consisted, in brief, of subtracting the vapor pressure of mercury, adjusted for the Poynting effect, from the observed pressure. This method does not take into account the effect on the pressure of the physical interaction of mercury vapor with fluorobenzene; but it is, at present, impossible to calculate accurately a correction for the interaction effect. For this reason the estimated experimental error reported for the gas compressibility at the higher temperatures and pressures has been arbitrarily increased to 0.3%. The gas compressibility measurements have been defined in sufficient detail so that a more accurate correction for the interaction effect of mercury vapor can be applied whenever a reliable method for calculating the correction becomes available.

A plot of the compressibility factor  $Z = PV/RT$  calculated from the experimental values of  $P$ ,  $V$  and  $T$ , Table VI, is given in Fig. 5.

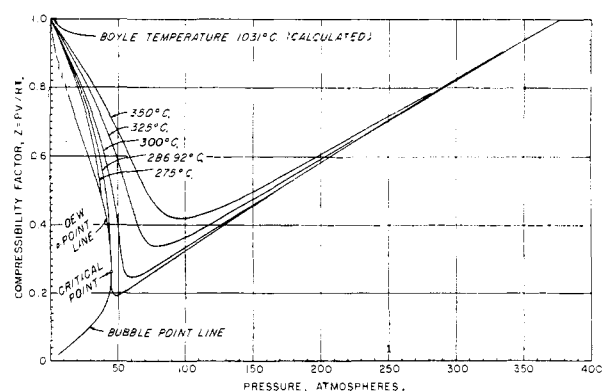

Fig. 5.—The compressibility of fluorobenzene in gaseous region.

TABLE VI

THE OBSERVED PRESSURE FOR FLUOROBENZENE COMPARED WITH THE PRESSURE CALCULATED FROM THE BEATTIE-BRIDGEMAN EQUATION OF STATE

Density, moles l. <sup>-1</sup> <i>t</i> , °C.(Int.)	Pressure, atm.												
	0.75	1.0	1.5	2.0	2.5	3.0	3.5	4.0	4.5	5.0	6.0	7.0	8.0
275.00 (obsd.)	25.104	30.173	36.449										
(obsd. - calcd.)	-0.172	-0.225	-0.319										
286.92 (obsd.)	26.098	31.609	39.031	42.864	44.440	44.863	44.908	44.912	45.063	46.187	61.188	128.94	327.93
(obsd. - calcd.)	-0.148	-0.175	-0.067	+0.217	+0.428	-0.011							
300 (obsd.)	27.173	33.156	41.654	46.691	49.513	51.124	52.235	53.345	55.057	58.481	80.743	159.11	374.52
(obsd. - calcd.)	-0.134	-0.144	+0.008	+0.343	+0.572	+0.074							
325 (obsd.)	29.200	36.046	46.499	53.720	58.822	62.772	66.315	70.189	75.342	83.318	119.23	218.89	
(obsd. - calcd.)	-0.129	-0.141	+0.013	+0.352	+0.542	+0.046							
350 (obsd.)	31.185	38.899	51.212	60.551	67.917	74.276	80.488	87.469	96.349	109.09	158.43	279.38	
(obsd. - calcd.)	-0.159	-0.161	-0.081	+0.224	+0.411	+0.021							
Av. dev., atm.	.148	.169	.098	.284	.488	.038							
Av. % dev.	.54	.50	.25	.57	.91	.07							

Total average % deviation, 0.47%.

**Virial Coefficients.**—The second and third virial coefficients  $B(T)$  and  $C(T)$ , defined by the equation

$$PV = RT(1 + B(T)/V + C(T)/V^2 + \dots) \quad (3)$$

were determined from the data of Table VI by graphically evaluating the zero-density intercepts of the quantities  $V(PV/RT - 1)$  and  $[V(PV/RT - 1) - B(T)]/V$ . The graphically determined values of the virial coefficients  $B(T)$  and  $C(T)$  are given in Table VII. To facilitate a comparison with theory, the experimental values of  $B(T)$  and  $C(T)$  are given in volume units of cubic centimeters per mole, and the temperatures are given on the thermodynamic scale<sup>15</sup> as well as on the International scale.

TABLE VII

SECOND AND THIRD VIRIAL COEFFICIENTS OF FLUOROBENZENE

<i>T</i> °K.(Int.)	<i>T</i> °K.(Thermo.)		<i>T</i> °C.	
	$\frac{-B(T)}{\text{cc. mole}^{-1}}$	$\frac{C(T)}{\text{cc.}^2 \text{ mole}^{-2}}$	$\times 10^{-3}$	$\times 10^{-4}$
548.16	548.26	378	49.5	
560.08	560.19	360	48.0	
573.16	573.28	341	45.8	
598.16	598.29	307	41.7	
623.16	623.30	279	39.8	

**Equation of State.**—Constants for the Beattie-Bridgeman equation of state,<sup>16</sup> given in Table VIII, have been derived from the compressibility data in the region from 0.75 to 3.0 mole l.<sup>-1</sup> and 286.92 to 350°. Because the Beattie-Bridgeman equation predicts isometrics with negative curvature, the practice on non-polar substances has been<sup>17</sup> to use the entire region below the critical density for evaluating the constants of the equation. However, the isometrics of fluorobenzene, like many polar substances, changed from a negative to a positive curvature somewhat below the critical density and therefore limited the application of the Beattie-Bridgeman equation to the region below 3.0 mole l.<sup>-1</sup>.

TABLE VIII

THE BEATTIE-BRIDGEMAN EQUATION OF STATE FOR FLUOROBENZENE

$$P = [RT(1 - \epsilon)/V^2][V + B] - A/V^2$$

$$A = A_0(1 - a/V)$$

$$B = B_0(1 - b/V)$$

$$\epsilon = c/VT^3$$

Units: normal atmospheres, liter mole<sup>-1</sup>, °K. (*T*, °K., = *t*, °C. + 273.16)

$$R = 0.0820544 \quad a = 0.14442 \quad b = 0.14688$$

$$A_0 = 33.8800 \quad B_0 = 0.41395 \quad c = 400 \times 10^4$$

Mol. wt. = 96.100<sup>(16)</sup>

The differences between the observed pressure and the pressure calculated from the Beattie-Bridgeman equation are listed in Table VI. The calculated values of the pressure differ, on the

(15) J. A. Beattie, "Temperature, Its Measurement and Control in Science and Industry," Vol. II, Reinhold Publ. Corp., New York, N. Y., 1935, Ch. 5.

(16) J. A. Beattie and O. C. Bridgeman, *Proc. Am. Acad. Arts Sci.*, **63**, 229 (1928).

(17) J. A. Beattie, D. R. Douslin and S. W. Levine, *J. Chem. Phys.*, **20**, 1619 (1952); J. A. Beattie, S. W. Levine and D. R. Douslin, *THIS JOURNAL*, **74**, 4778 (1952).

average, from the experimental values by three or four times the estimated error in the measurements.

**Intermolecular Potential Energy and the Boyle Temperature.**—Stockmayer's classical statistical equation for the temperature dependency of the second virial coefficient of polar gases<sup>18</sup>

$$B(T) = b_0 F(\tau, t) \quad (4)$$

and the equation for the zero pressure limit of the partial derivative of vapor heat capacity with respect to pressure at constant temperature

$$\lim_{p \rightarrow 0} \left( \frac{\partial C_p}{\partial p} \right)_T = -b_0/T \partial^2 F(\tau, t) / \partial T^2 \quad (5)$$

were used with experimental values of the second virial coefficient and vapor heat capacity to obtain the three adjustable intermolecular potential energy parameters  $b_0 = 0.1995$  liter mole<sup>-1</sup>,  $\theta = 302^\circ\text{K}$ . and  $t = 0.9$ . Equations 4 and 5, written here in functional notation, are based on Stockmayer's 6-12 potential energy equation for polar gases

$$U(r) = 4k\theta \left[ \left( \frac{3b_0}{2\pi N r^3} \right)^4 - \left( \frac{3b_0}{2\pi N r^3} \right)^2 - \frac{\sqrt{2}}{2} t g \left( \frac{3b_0}{2\pi N r^3} \right) \right] \quad (6)$$

where

$$\theta = T/\tau = E/k \quad (7)$$

$$T = ^\circ\text{K. (Thermo.)} \quad (8)$$

$$b_0 = 2/3\pi N \sigma^3 \quad (9)$$

$$t = (\mu^2/E\sigma^3)/\sqrt{8} \quad (10)$$

and  $\mu$  is the dipole moment. For any asymmetrical polar molecule, the maximum energy of interaction  $E$  and the collision diameter  $\sigma$  can only be evaluated from macroscopic properties as mean values representing an average for all possible relative orientations of the molecules. Therefore  $E$  and  $\sigma$  do not have quite the same significance in equations 4 and 5 as they do in the corresponding Lennard-Jones equations that are based upon a central force field in which orientation of the molecule is not a factor.

In the application of Stockmayer's potential energy equation to fluorobenzene, each of the three potential energy parameters was assumed to be adjustable without being subject to the conditions or restraints of equation 10; thus, the parameter  $t$  was used to represent all of the orientational effects instead of being limited to the dipole-dipole interaction. A report previously was made of the successful use of the above method for evaluating the potential energy parameters of carbon dioxide, benzene, nitromethane and fluorobenzene.<sup>19</sup> These molecules were chosen to test the method because they included a variety of types of orientational forces. For a moderately polar, asymmetrical molecule like fluorobenzene, for which the angular-dependent dipole forces are responsible for only

part of the total orientational effect, the use of  $t$  in this more general, but more empirical, manner is certainly a more logical procedure than somehow forcing an adjustment of  $b_0$  and  $\theta$  by using the orientational parameter  $t$  exclusively for the dipole-dipole effect. The evaluation of potential energy parameters for Stockmayer's equation from experimental values of the second virial coefficient and the dipole moment, by means of equation 10, is only justified for highly polar, spherical or nearly-spherical molecules like water, nitromethane or acetonitrile.

Although many types of angular-dependent forces are large enough to be quite easily detectable in the second virial coefficient or the pressure derivative of vapor heat capacity, it is not possible to identify the different types of angular-dependent forces from these macroscopic physical properties because, within the accuracy of the best modern measurements, all of the angular-dependent forces appear to generate the same kind of temperature dependence. Pople<sup>20</sup> has found, for axially symmetrical molecules with non-central force fields, that if the angular-dependent forces are treated as perturbations on the central forces (*i.e.*, if the angular-dependence of the force fields is small) and if only the leading perturbation term is retained, that different types of orientational interaction cannot be distinguished in the second virial coefficient. The lack of specificity in the temperature dependence of the second virial coefficient is the reason why the parameter  $t$  can be used to represent other orientational effects, as well as the dipole effect, in fluorobenzene.

A description of the method of superimposed logarithmic plots, which was used to obtain the foregoing values of the three adjustable parameters of the Stockmayer potential energy equation, has been given in detail in a previous pub-

TABLE IX

A COMPARISON OF THE OBSERVED AND CALCULATED VALUES OF THE SECOND VIRIAL COEFFICIENT OF FLUOROBENZENE

$T, ^\circ\text{K. (Thermo.)}$	$(-B(T), \text{cc. mole}^{-1})$	
	Obsd.	Calcd. eq. 4b
302.00	..	1680
318.39	1439 <sup>a</sup>	1450
336.78	1263 <sup>a</sup>	1248
357.89	1079 <sup>a</sup>	1060
382.37	905 <sup>a</sup>	898
422.80	..	702
483.20	..	511
548.26	378	378
560.19	360	359
573.16	341	340
598.29	307	306
623.30	279	277
694.60	..	209
966.40	..	72
1304.0	..	0

<sup>a</sup> Calculated from the Clapeyron equation and the experimental vapor pressure and heat of vaporization data given in ref. 2. <sup>b</sup> Numerical values of the parameters used in equation 4 are:  $b_0 = 0.1995$  liter mole<sup>-1</sup>,  $\theta = 302^\circ\text{K}$ . and  $t = 0.9$ .

(18) (a) H. S. Taylor and S. Glasstone, "Treatise on Physical Chemistry," Vol. II, D. Van Nostrand Co., Inc., New York, N. Y., 1951, Ch. II, "Thermodynamics and Statistical Mechanics," by J. A. Beattie and W. H. Stockmayer; (b) W. H. Stockmayer, *J. Chem. Phys.*, **9**, 398 (1941).

(19) D. R. Douslin and Guy Waddington, "Intermolecular Potential Energies from the Pressure Derivative of Vapor Heat Capacity," presented before the Division of Physical and Inorganic Chemistry, American Chemical Society, Minneapolis, Minnesota, September 12, 1955.

(20) J. A. Pople, *Proc. Royal Soc. (London)*, **A221**, 508 (1954).

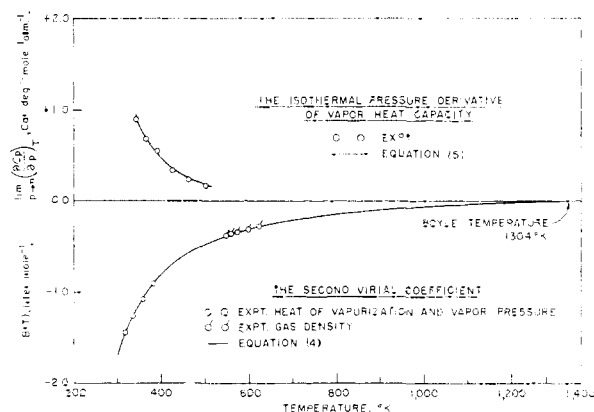

Fig. 6.—The second virial coefficient and the zero pressure limit of the isothermal pressure derivative of the vapor heat capacity of fluorobenzene.

lication.<sup>21</sup> A tabulation of the second virial coefficient function  $F(\tau, t)$  that was used in determining the parameters has been given by Rowlinson<sup>22</sup> for the ranges  $0.3 < \tau < 400$  and  $0 < t < 1.5$ ; and a tabulation of the heat capacity function  $\partial^2 F(\tau, t)/\partial T^2$  was given in ref. 21 for the ranges  $0.5 < \tau < 3$  and  $0 < t < 1.6$ .<sup>23</sup> The observed values of the second virial coefficient that were used in determining the parameters are given in column 2 of Table IX. Between the temperatures 318.39 and 382.37°K., the observed values of  $B(T)$  were determined from the Clapeyron equation and experimental vapor pressure and heat of vaporization data.<sup>2</sup> The observed values of  $B(T)$  in the temperature range 548.26 to 623.30°K. are from Table

(21) D. R. Douslin and G. Waddington, *J. Chem. Phys.*, **23**, 2453 (1955).

(22) J. S. Rowlinson, *Trans. Faraday Soc.*, **54**, 974 (1949).

(23) The tabulated values for the heat capacity function were calculated from the  $P_j^{(2)}$  functions appearing in the report "The Virial Equation of State," by R. B. Bird and E. L. Spatz, University of Wisconsin CM-599 (1950).

VII. The observed values of  $\lim_{p \rightarrow 0} (\partial C_p / \partial p)_T$ , given in column 2 of Table X, were evaluated graphically from the molal heat capacity data of fluorobenzene given in Table X of reference 2.

TABLE X

A COMPARISON OF THE OBSERVED AND CALCULATED VALUES OF THE ISOTHERMAL PRESSURE DERIVATIVE OF VAPOR HEAT CAPACITY OF FLUOROBENZENE

$T, ^\circ\text{K. (Thermo.)}$	$\lim_{p \rightarrow 0} (\partial C_p / \partial p)_T, \text{ cal. deg.}^{-1} \text{ mole}^{-1} \text{ atm.}^{-1}$	Obsd. <sup>a</sup>	Calcd. eq. 5 <sup>b</sup>
343.19		0.90	0.92
364.20		.69	.69
389.21		.52	.51
426.23		.34	.34
463.25		.24	.24
500.27		.18	.18
513.40		..	.16
543.60		..	.13
604.00		..	.09
634.20		..	.08

<sup>a</sup> Evaluated, graphically, from the experimental values of the molal vapor heat capacity of fluorobenzene given in Table X of ref. 2. <sup>b</sup> The numerical values of the parameters used in equation 5 are:  $b_0 = 0.1995$  liter mole<sup>-1</sup>,  $\theta = 302^\circ\text{K.}$  and  $t = 0.9$ .

The method described above for treating the three parameters  $b_0$ ,  $\theta$  and  $t$  appears to be justified by the agreement between observed and calculated values of  $B(T)$  and  $\lim_{p \rightarrow 0} (\partial C_p / \partial p)_T$  for fluorobenzene. The calculated values for  $\lim_{p \rightarrow 0} (\partial C_p / \partial p)_T$  which are shown in column 3 of Table X agree with the observed values within the experimental accuracy. Likewise, the calculated values for  $B(T)$  listed in column 3 of Table IX agree with the observed values within the experimental accuracy over a temperature range in excess of 300°. The calculated values for  $B(T)$  are shown in Fig. 6 up to the Boyle temperature 1304°K.

BARTLESVILLE, OKLAHOMA

[CONTRIBUTION FROM THE RADIATION LABORATORY AND DEPARTMENT OF CHEMISTRY, UNIVERSITY OF CALIFORNIA, BERKELEY]

## The Heat, Free Energy and Entropy of the Ferrate(VI) Ion

BY ROBERT H. WOOD<sup>1</sup>

RECEIVED JULY 26, 1957

The heat of the reaction of aqueous  $\text{K}_2\text{FeO}_4$  with perchloric acid (0.5 mole per kg. of water) to give  $\text{O}_2$  and  $\text{Fe}^{+3}$  has been measured at 25°. From this datum the heat of formation of  $\text{FeO}_4^{2-}(\text{aq.})$  ( $\Delta H_f^\circ = -115 \pm 1$  kcal./mole) has been calculated. The entropy of  $\text{FeO}_4^{2-}(\text{aq.})$  has been estimated as  $9 \pm 4$  e.u. From these values the free energy of formation of  $\text{FeO}_4^{2-}(\text{aq.})$  has been calculated; it is  $\Delta F_f^\circ = -77 \pm 2$  kcal./mole. The standard electromotive force of the half reaction  $\text{Fe}(\text{OH})_3 + 5\text{OH}^- \rightarrow \text{FeO}_4^{2-} + 4\text{H}_2\text{O} + 3e^-$  has been estimated as  $E^\circ = -0.72 \pm 0.03$  volt. It has been verified that the ferrate ion at pH 10 is a dinegative species which decomposes only slowly. A method of analysis for aqueous  $\text{K}_2\text{FeO}_4$  has been developed in which ferric hydroxide is removed by filtration and the total iron present is measured. This analysis has been shown to be accurate to better than  $\pm 1\%$  by comparison with the volume of oxygen liberated on acidifying an aqueous  $\text{K}_2\text{FeO}_4$  solution. The absorption spectrum of  $\text{K}_2\text{FeO}_4$  has been measured.

### Introduction

Although good methods for preparing and analyzing  $\text{K}_2\text{FeO}_4$  have been described recently,<sup>2a-c</sup>

(1) Abstracted in part from thesis, Robert H. Wood, University of California Radiation Laboratory unclassified document, UCRL-3751, 1957. The present address of the author is The University of Delaware, Newark, Delaware.

(2) (a) G. W. Thompson, L. T. Ockerman and J. M. Schreyer, *This*

no measurements of the thermodynamic constants of the aqueous ferrate(VI) ion have appeared in the

*JOURNAL*, **73**, 1379 (1951); (b) Von R. Scholder, H. V. Bunsen, F. Kindervater and W. Zeiss, *Z. anorg. allgem. Chem.*, **282**, 268 (1955).

(3) J. M. Schreyer, G. W. Thompson and L. T. Ockerman, *Anal. Chem.*, **22**, 691 (1950).

(4) J. M. Schreyer, G. W. Thompson and L. T. Ockerman, *ibid.*, **22**, 1426 (1950).